

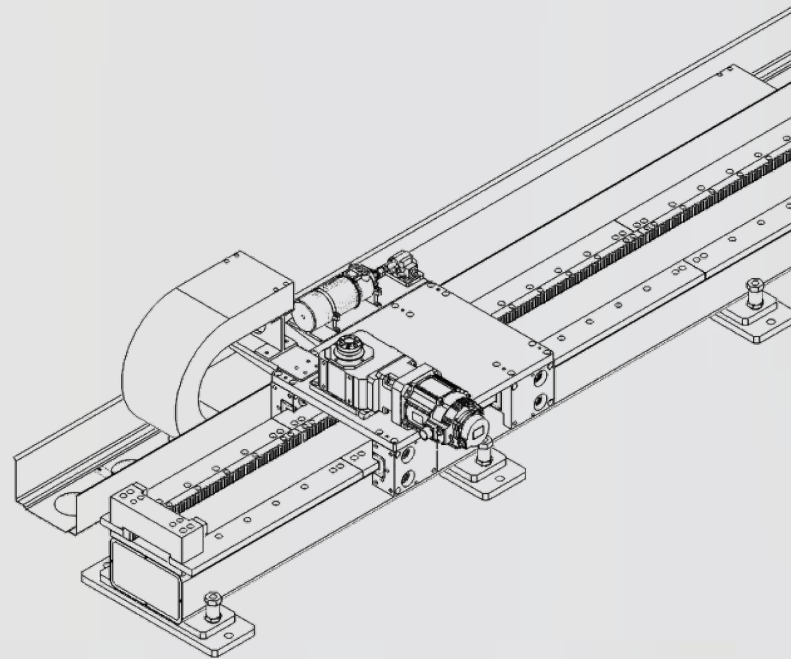

**摩云阁**  
MOVING-GOODS

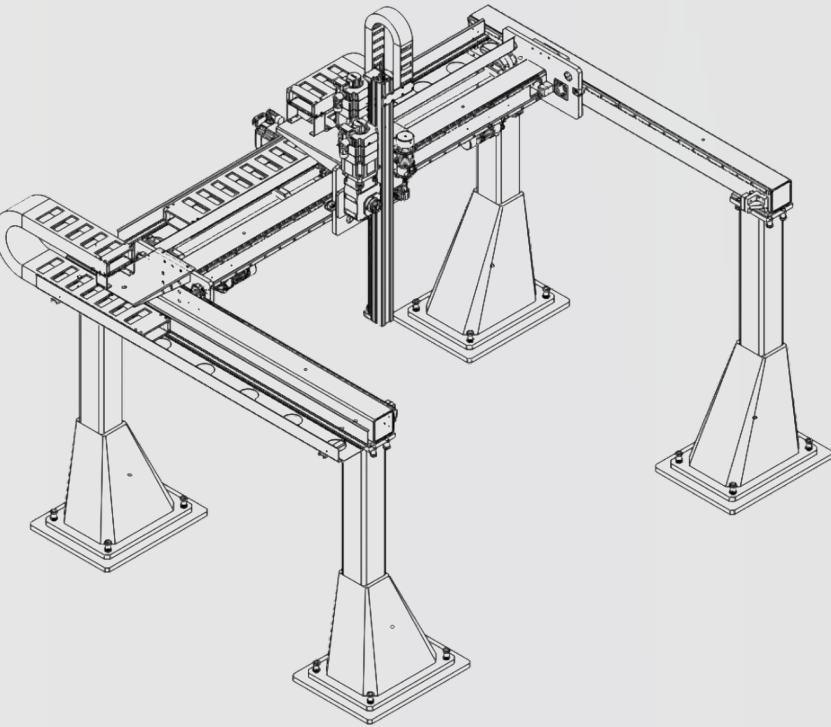
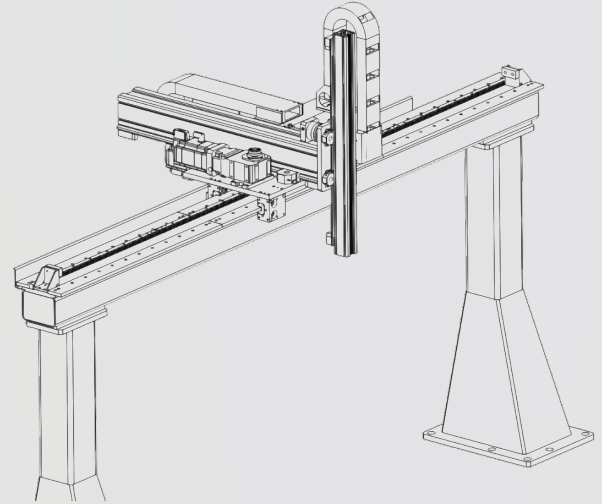
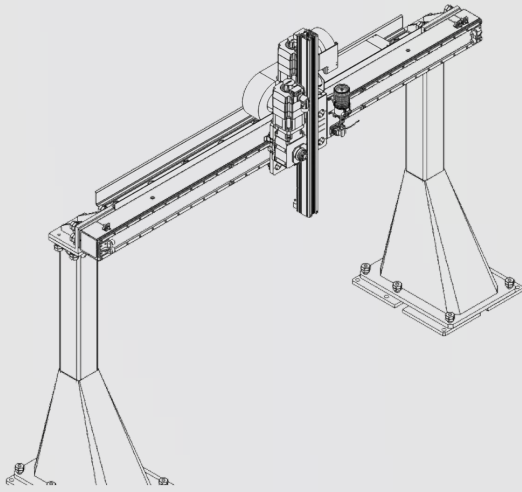

**摩云阁香河机器人有限公司**  
BMG Robot (Xianghe) Co., Ltd.

# 直行有道 智控无疆

Smarter Linear Motion



精密 高速 可靠

Precision Speed Reliability



跨行业自动化解决方案

Multi-Industry Automation Solutions

# 目录

## Contents

<b>1. 公司简介 Company Profile</b>	<b>01</b>
<b>2. 桁架机器人 Gantry Robots</b>	<b>05</b>
2.1.1 单梁两轴桁架机器人CG-15 Single-beam 2-axis Gantry Robot CG-15	06
2.1.2 单梁两轴桁架机器人CG-40 Single-beam 2-axis Gantry Robot CG-40	07
2.1.3 单梁两轴桁架机器人CG-150 Single-beam 2-axis Gantry Robot CG-150	08
2.1.4 单梁两轴桁架机器人CG-400 Single-beam 2-axis Gantry Robot CG-400	09
2.1.5 单梁两轴桁架机器人CG-1200 Single-beam 2-axis Gantry Robot CG-1200	10
2.1.6 单梁两轴桁架机器人CG-3000 Single-beam 2-axis Gantry Robot CG-3000	11
2.2.1 单梁三轴桁架机器人TG-15 Single-beam 3-axis Gantry Robot TG-15	12
2.2.2 单梁三轴桁架机器人TG-40 Single-beam 3-axis Gantry Robot TG-40	13
2.2.3 单梁三轴桁架机器人TG-150 Single-beam 3-axis Gantry Robot TG-150	14
2.3.1 龙门三轴桁架机器人HG-15 Double-beam 3-axis Gantry Robot HG-15	15
2.3.2 龙门三轴桁架机器人HG-40 Double-beam 3-axis Gantry Robot HG-40	16
2.3.3 龙门三轴桁架机器人HG-150 Double-beam 3-axis Gantry Robot HG-150	17
2.3.4 龙门三轴桁架机器人HG-400 Double-beam 3-axis Gantry Robot HG-400	18
2.3.5 龙门三轴桁架机器人HG-1000 Double-beam 3-axis Gantry Robot HG-1000	19
2.3.6 龙门三轴桁架机器人HG-2500 Double-beam 3-axis Gantry Robot HG-2500	20
<b>3. 机器人行走轴 Travelling Tracks for Robots</b>	<b>21</b>
3.1.1 机器人行走轴GT-300 Travelling Track for Robot GT-300	22
3.1.2 机器人行走轴GT-900 Travelling Track for Robot GT-900	23
3.1.3 机器人行走轴GT-2000 Travelling Track for Robot GT-2000	24
3.1.4 机器人行走轴GT-3000 Travelling Track for Robot GT-3000	25
<b>4. 自动化解决方案 Automation Solutions</b>	<b>26</b>
4.1.1 机器人行走轴GT-300 Travelling Track for Robot GT-300	27
4.1.2 机器人行走轴GT-900 Travelling Track for Robot GT-900	28
<b>5. 客户需求参数表 Customer Request Form</b>	<b>29</b>

## 关于摩云阁

### About MOVING-GOODS

北京摩云阁精密齿条股份有限公司成立于2010年，是中国领先的精密齿条传动系统和桁架机器人制造商，自动化解决方案供应商。我们的产品从精密齿条/齿轮、齿条传动系统延伸到基于这些传动技术的桁架机器人、机器人行走轴及自动化生产线。



摩云阁公司总部位于北京市通州区，是北京市高新技术企业，全资子公司——摩云阁香河机器人有限公司及工厂位于河北香河经济开发区机器人小镇。公司已通过ISO9001质量体系认证，拥有强大的技术研发团队和多项核心专利，自主研发的M7150高精度数控齿条磨齿机加工精度达到国际领先水平。

摩云阁精密齿条及桁架机器人系列产品以“精密、高速、可靠”闻名，赢得了全球客户的认可与信赖，广泛应用于机床、机器人、汽车、航空航天、半导体、医疗、制药、新能源、物流、工厂自动化、激光设备、塑料机械、测量仪器、工程机械、矿山机械、农业机械、木工机械等多个行业。

Founded in 2010, Beijing Moving-Goods Precision Racks Co., Ltd. is a leading manufacturer of precision rack drive systems and gantry robots, as well as a provider of automation solutions. Characterized by innovation, high quality and modular design, our product portfolio ranges from precision racks and pinions, V-type/flat rail guideway rack drive systems to gantry robots, robot travelling axes, and automated production lines based on linear transmission technologies.

MOVING-GOODS is headquartered in Beijing, China, and is recognized as a Beijing High-Tech Enterprise. Its wholly-owned subsidiary, BMG Robot (Xianghe) Co., Ltd., together with its production base is located in Hebei. Certified with ISO 9001, the company boasts a robust R&D team and numerous core patents. Notably, our independently developed M7150 High-Precision CNC Rack Grinding Machine achieves top accuracy among global standards.

Renowned for “Precision, Speed and Reliability”, MOVING-GOODS’ racks and gantry robots series have gained recognition and trust from customers worldwide. Our products are widely used in machine tools, robotics, automotive, aerospace, semiconductor, medical, pharmaceutical, new energy, logistics, factory automation, laser, plastic, measuring and testing, construction, mining, agriculture, woodworking and many other industries.

# 荣誉资质 Honors & Qualifications





# 发展历程

## Milestones

**2002年**

北京摩云阁建筑器材制造有限公司齿条事业部成立

Rack Division of Beijing Moving-Goods Construction Machinery Manufacturing Co., Ltd. is established.

**2010年**

北京摩云阁精密齿条有限公司成立

Beijing Moving-Goods Precision Racks Co., Ltd. was founded.

**2019年**

北京摩云阁精密齿条股份有限公司在新三板上市，股票代码：873218

Beijing Moving-Goods Precision Racks Co., Ltd. was listed on the NEEQ under Stock Code: 873218.

**2009年**

自主研发M7150高精度数控齿条磨齿机，加工精度达到国际领先水平

Independently developed M7150 High-Precision CNC Rack Grinding Machine, achieving world-leading machining accuracy.

**2017年**

成立全资子公司——摩云阁香河机器人有限公司，推出桁架机器人、机器人第七轴等新产品

Established wholly owned subsidiary - BMG Robot (Xianghe) Co., Ltd. and launched new products including gantry robots and 7th axis for robots.

# 全球合作伙伴

## Global Partners

**JIER**  
济南二机床集团

  
**通用技术**  
GENERTEC  
好技术·好生活

  
**武重集团**

  
**中国一重**  
CFHI

  
**中汽工程**

**HDCNC**  
华东数控

**JEE** **FET**

  
**HGTECH**  
LASER

**FARLEY-LASERLAB**  
国际品质 智领未来

**Yawei** 亚威

  
**JRDH**

**CHR** 畅尔

  
海德曼

  
**MINO**  
Create value with our heart

**JFY** 金方圆

**TRUMPF**

**bodur**

**WAMIT**

**DERATECK**

**AUTOBOX**

  
**DELTA**

**SIEMENS**

**STAR**

**SIASUN** 新松

  
**ACE STEP**  
同步自动化

**AEH**

**NBT** 诺博特

**FANUC**

**ABB**

**KUKA**

**YASKAWA**

  
**MECH MIND**

**HIKVISION**

  
**C.P.GROUP**

  
**正大集团**  
CP GROUP



## 桁架机器人 Gantry Robots

摩云阁桁架机器人系列产品包含单梁两轴桁架机器人-CG系列、单梁三轴桁架机器人-TG系列、龙门三轴桁架机器人-HG系列等。基于摩云阁V型导轨齿条传动系统和扁导轨齿条传动系统设计，具有模块化、精度高、速度快、结构紧凑、低噪音等优势。最大负载能力从15kg-3000kg提供多款选择。

与台达、西门子、发那科、ABB、库卡、安川等品牌的战略合作，可为桁架机器人配置多款伺服控制系统、机械臂和抓手。

MOVING-GOODS Gantry Robots Series includes Single-beam 2-axis Gantry Robots (CG Series), Single-beam 3-axis Gantry Robots (TG Series), and Double-beam 3-axis Gantry Robots (HG Series). Designed based on MOVING-GOODS Guideway Rack Drive Systems, the products feature modular design, high precision, high speed, space-saving and low noise. Models available with maximum payload from 15kg to 3000kg.

Through strategic partnerships with Delta, Siemens, FANUC, ABB, KUKA, Yaskawa and other brands, we can equip gantry robots with a variety of servo control systems, robotic arms and grippers.

单梁两轴桁架机器人CG-15  
Single-beam 2-axis gantry robot CG-15

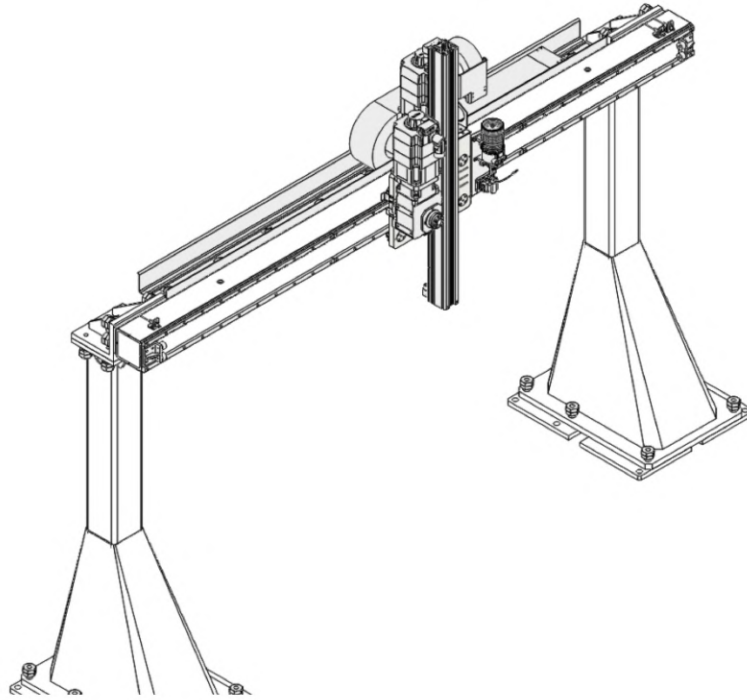

最大负载能力 Max. Payload	15kg
X轴最大移动速度 Max. Speed for X axis	150m/min.
X轴最大加速度 Max. acc. Speed for X axis	6 m/s <sup>2</sup>
Z轴最大移动速度 Max. Speed for Z axis	120m/min.
Z轴最大加速度 Max. acc. Speed for Z axis	10m /s <sup>2</sup>
Z轴标准行程 Standard stroke for Z axis	700mm
重复定位精度 Repeatability accuracy	±0.02mm
驱动方式 Drive	齿轮齿条 Rack & pinion
控制方式 El. Control	伺服控制 Servo control

X轴

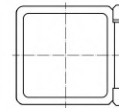

Z轴



**单梁两轴桁架机器人CG-40**  
**Single-beam 2-axis gantry robot CG-40**

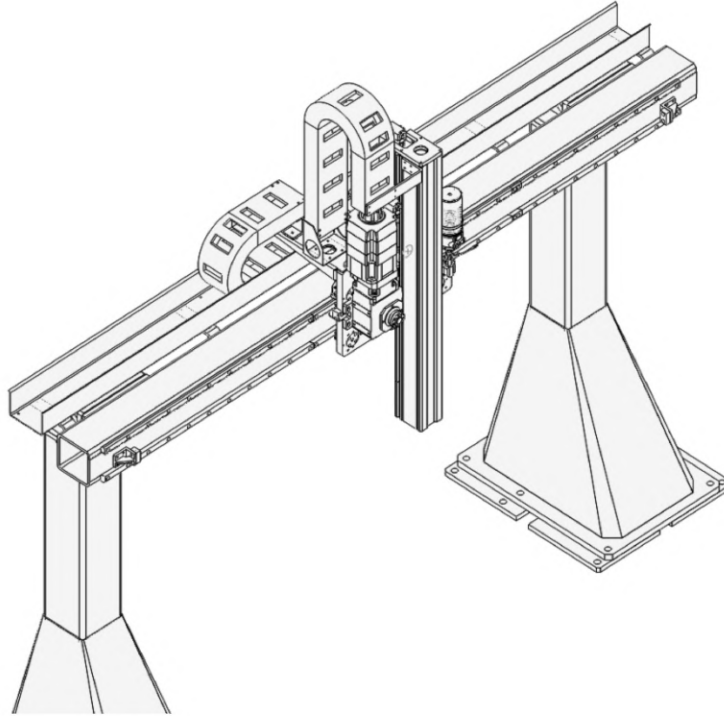

最大负载能力 Max. Payload	40kg
X轴最大移动速度 Max. Speed for X axis	120m/min.
X轴最大加速度 Max. acc. Speed for X axis	4 m/s <sup>2</sup>
Z轴最大移动速度 Max. Speed for Z axis	75m/min.
Z轴最大加速度 Max. acc. Speed for Z axis	3m /s <sup>2</sup>
Z轴标准行程 Standard stroke for Z axis	1000mm
重复定位精度 Repeatability accuracy	±0.02mm
驱动方式 Drive	齿轮齿条 Rack & pinion
控制方式 El. Control	伺服控制 Servo control

X轴

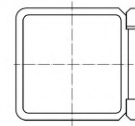

Z轴

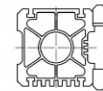

单梁两轴桁架机器人CG-150  
Single-beam 2-axis gantry robot CG-150

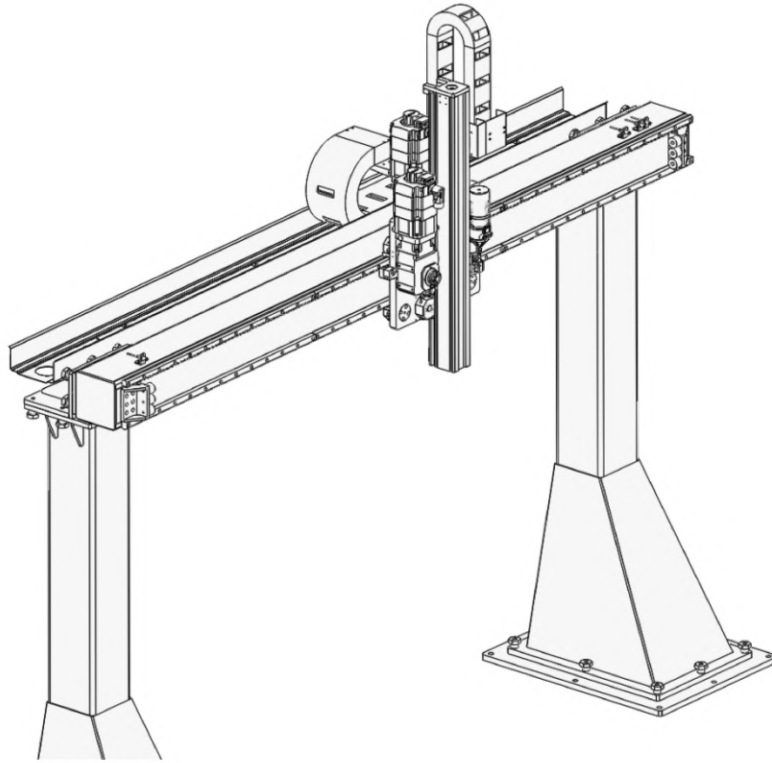

最大负载能力 Max. Payload	150kg
X轴最大移动速度 Max. Speed for X axis	60 m/min.
X轴最大加速度 Max. acc. Speed for X axis	2 m/s <sup>2</sup>
Z轴最大移动速度 Max. Speed for Z axis	42 m/min
Z轴最大加速度 Max. acc. Speed for Z axis	1m/s <sup>2</sup>
Z轴标准行程 Standard stroke for Z axis	1200mm
重复定位精度 Repeatability accuracy	±0.02mm
驱动方式 Drive	齿轮齿条 Rack & pinion
控制方式 El. Control	伺服控制 Servo control

X轴

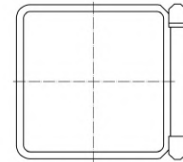

Z轴

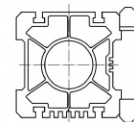

**单梁两轴桁架机器人CG-400**  
**Single-beam 2-axis gantry robot CG-400**

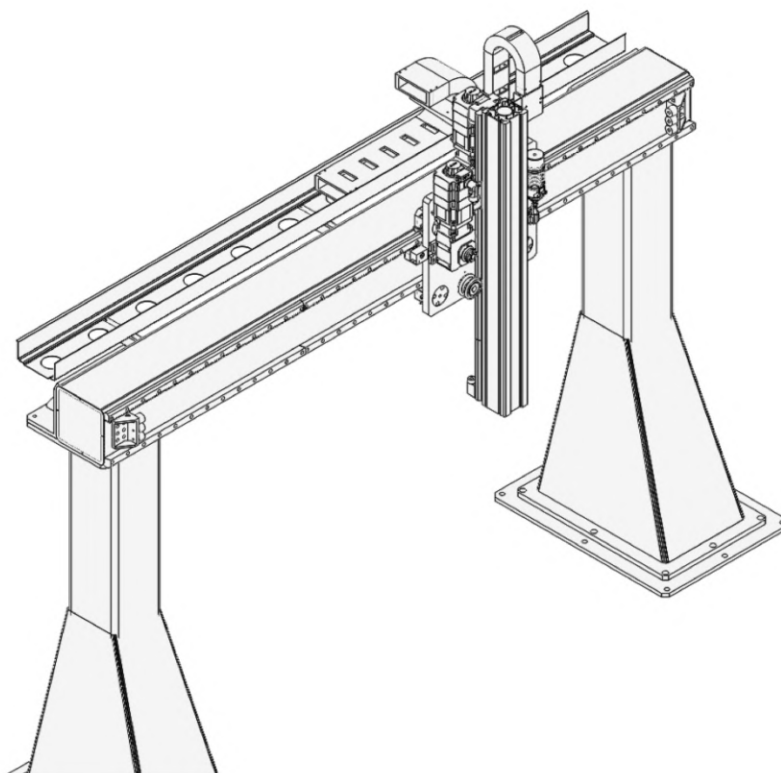

最大负载能力 Max. Payload	400kg
X轴最大移动速度 Max. Speed for X axis	60 m/min.
X轴最大加速度 Max. acc. Speed for X axis	2 m/s <sup>2</sup>
Z轴最大移动速度 Max. Speed for Z axis	36 m/min
Z轴最大加速度 Max. acc. Speed for Z axis	1m/s <sup>2</sup>
Z轴标准行程 Standard stroke for Z axis	1600mm
重复定位精度 Repeatability accuracy	±0.02mm
驱动方式 Drive	齿轮齿条 Rack & pinion
控制方式 El. Control	伺服控制 Servo control

X轴

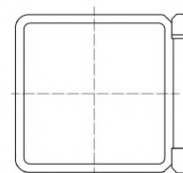

Z轴

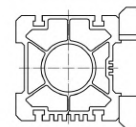

**单梁两轴桁架机器人CG-1200**  
**Single-beam 2-axis gantry robot CG-1200**

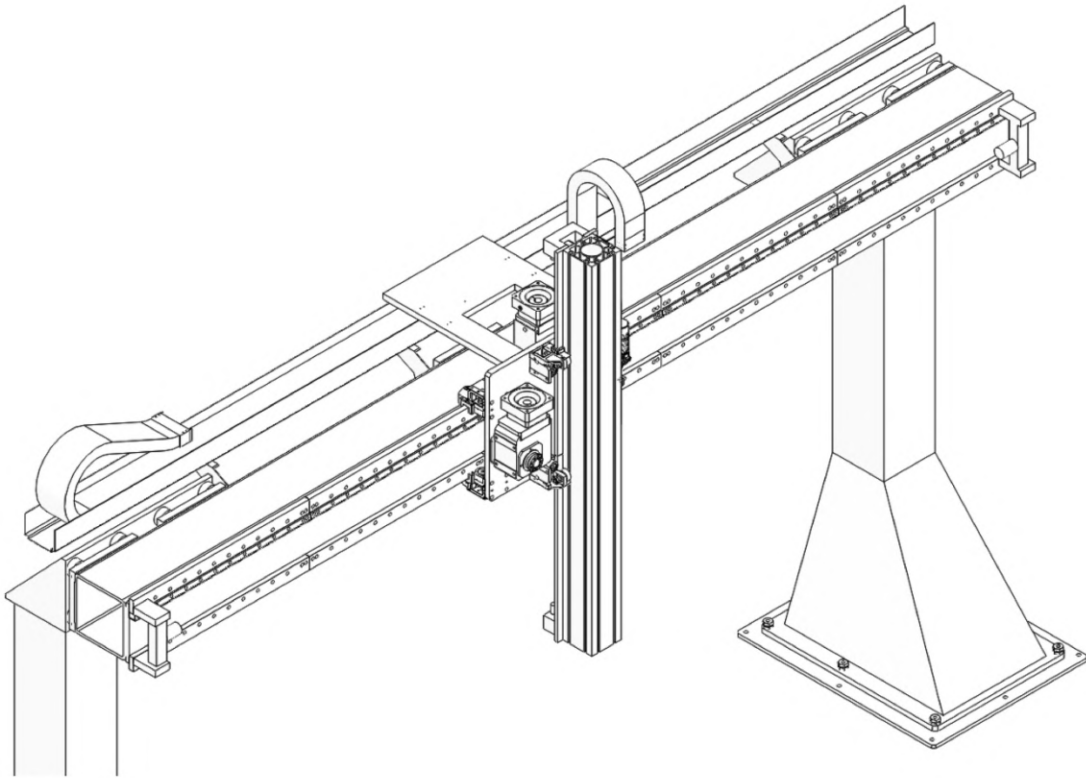

最大负载能力 Max. Payload	1200kg
X轴最大移动速度 Max. Speed for X axis	60 m/min.
X轴最大加速度 Max. acc. Speed for X axis	2 m/s <sup>2</sup>
Z轴最大移动速度 Max. Speed for Z axis	30 m/min
Z轴最大加速度 Max. acc. Speed for Z axis	1m/s <sup>2</sup>
Z轴标准行程 Standard stroke for Z axis	1600mm
重复定位精度 Repeatability accuracy	±0.02mm
驱动方式 Drive	齿轮齿条 Rack & pinion
控制方式 El. Control	伺服控制 Servo control

X轴

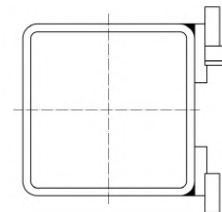

Z轴

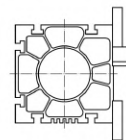

**单梁两轴桁架机器人CG-3000**  
**Single-beam 2-axis gantry robot CG-3000**

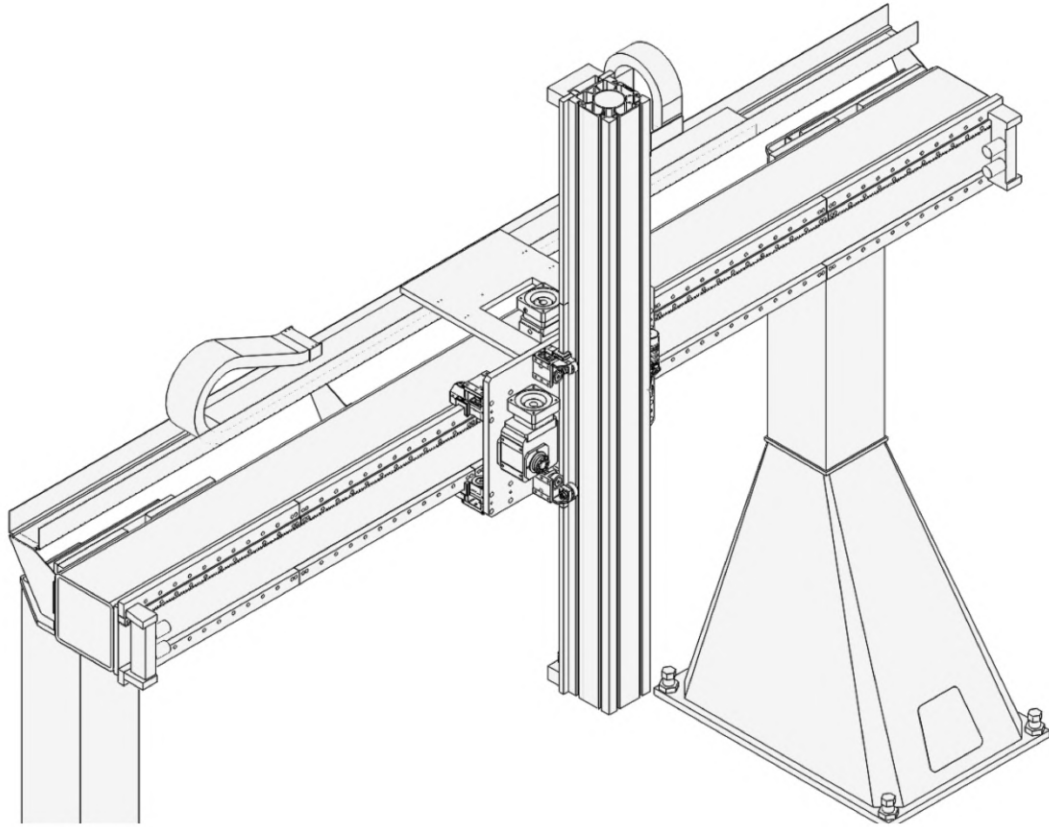

最大负载能力 Max. Payload	3000kg
X轴最大移动速度 Max. Speed for X axis	60 m/min.
X轴最大加速度 Max. acc. Speed for X axis	2 m/s <sup>2</sup>
Z轴最大移动速度 Max. Speed for Z axis	30 m/min
Z轴最大加速度 Max. acc. Speed for Z axis	1m/s <sup>2</sup>
Z轴标准行程 Standard stroke for Z axis	1600mm
重复定位精度 Repeatability accuracy	±0.02mm
驱动方式 Drive	齿轮齿条 Rack & pinion
控制方式 El. Control	伺服控制 Servo control

X轴

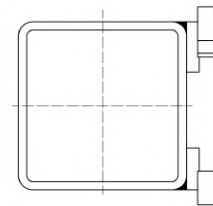

Z轴

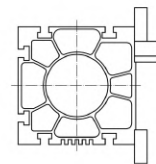

**单梁三轴桁架机器人 TG-15**  
**Single-beam 3-axis gantry robot TG-15**

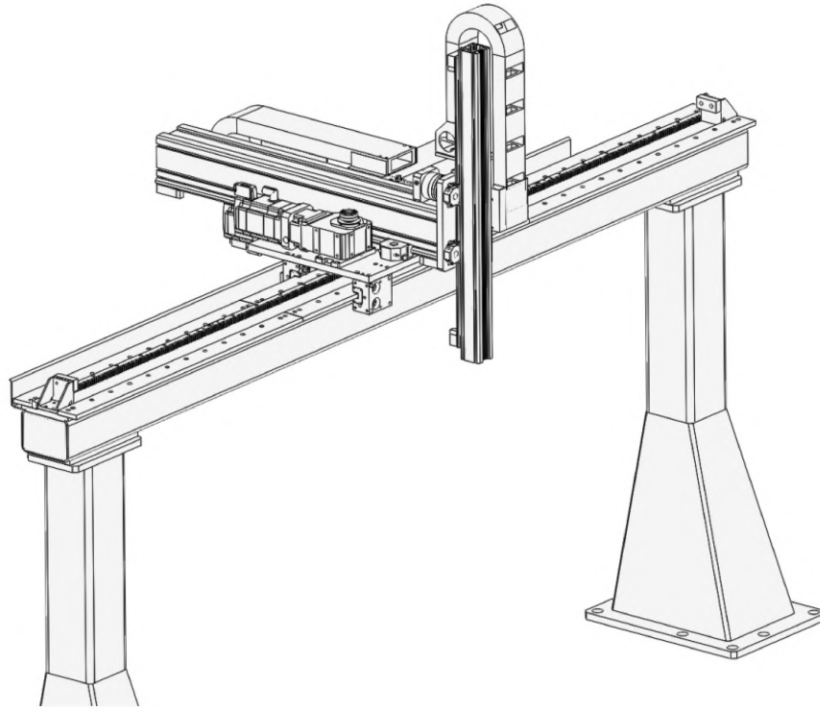

最大负载能力 Max. Payload	15kg
X轴最大移动速度 Max. Speed for X axis	120m/min.
X轴最大加速度 Max. acc. Speed for X axis	2 m/s <sup>2</sup>
Y轴最大移动速度 Max. Speed for Y axis	90m/min.
Y轴最大加速度 Max. acc. Speed for Y axis	3m/s <sup>2</sup>
Z轴最大移动速度 Max. Speed for Z axis	90m/min.
Z轴最大加速度 Max. acc. Speed for Z axis	5m /s <sup>2</sup>
Y轴标准行程 Standard stroke for Y axis	600mm
Z轴标准行程 Standard stroke for Z axis	700mm
重复定位精度 Repeatability accuracy	±0.02mm
驱动方式 Drive	齿轮齿条 Rack & pinion
控制方式 El. control	伺服控制 Servo control

X轴

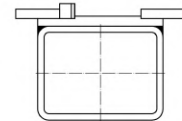

Y轴

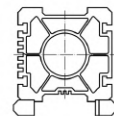

Z轴



**单梁三轴桁架机器人TG-40**  
**Single-beam 3-axis gantry robot TG-40**

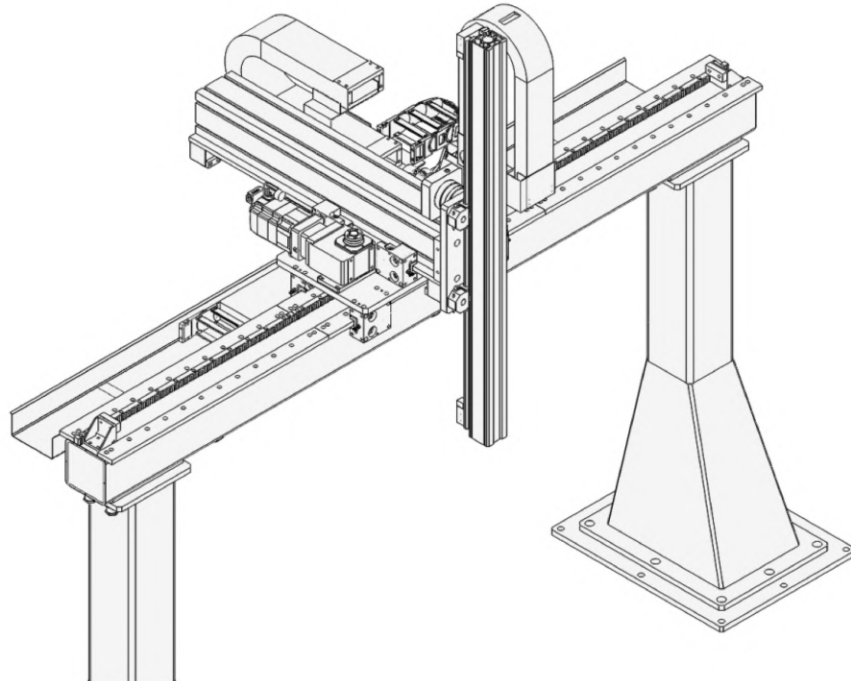

最大负载能力 Max. Payload	40kg
X轴最大移动速度 Max. Speed for X axis	120m/min.
X轴最大加速度 Max. acc. Speed for X axis	2 m/s <sup>2</sup>
Y轴最大移动速度 Max. Speed for Y axis	90m/min.
Y轴最大加速度 Max. acc. Speed for Y axis	3m/s <sup>2</sup>
Z轴最大移动速度 Max. Speed for Z axis	60m/min.
Z轴最大加速度 Max. acc. Speed for Z axis	3m /s <sup>2</sup>
Y轴标准行程 Standard stroke for Y axis	1000mm
Z轴标准行程 Standard stroke for Z axis	1000mm
重复定位精度 Repeatability accuracy	±0.02mm
驱动方式 Drive	齿轮齿条 Rack & pinion
控制方式 El. control	伺服控制 Servo control

X轴

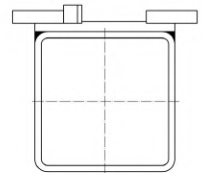

Y轴

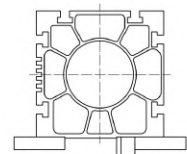

Z轴



### 单梁三轴桁架机器人 TG-150

#### Single-beam 3-axis gantry robot TG-150

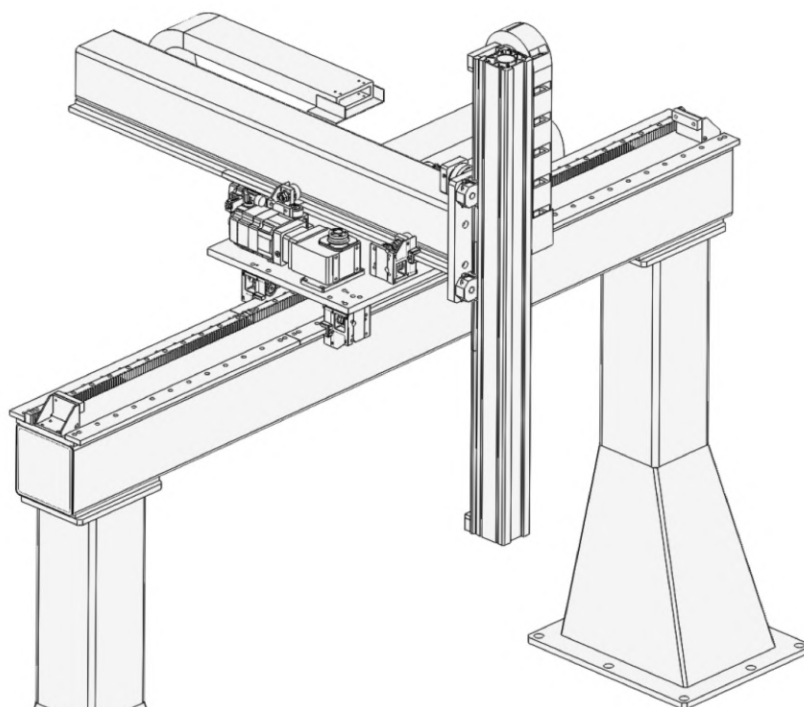

最大负载能力 Max. Payload	150kg
X轴最大移动速度 Max. Speed for X axis	60m/min.
X轴最大加速度 Max. acc. Speed for X axis	1 m/s <sup>2</sup>
Y轴最大移动速度 Max. Speed for Y axis	60m/min.
Y轴最大加速度 Max. acc. Speed for Y axis	2m/s <sup>2</sup>
Z轴最大移动速度 Max. Speed for Z axis	42m/min.
Z轴最大加速度 Max. acc. Speed for Z axis	1m /s <sup>2</sup>
Y轴标准行程 Standard stroke for Y axis	1000mm
Z轴标准行程 Standard stroke for Z axis	1200mm
重复定位精度 Repeatability accuracy	±0.02mm
驱动方式 Drive	齿轮齿条 Rack & pinion
控制方式 El. control	伺服控制 Servo control

X轴

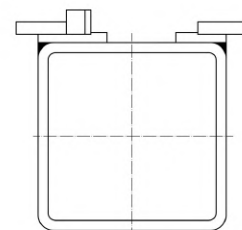

Y轴

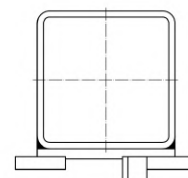

Z轴

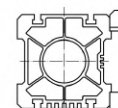

### 龙门三轴桁架机器人 HG-15

#### Double-beam 3-axis gantry robot HG-15

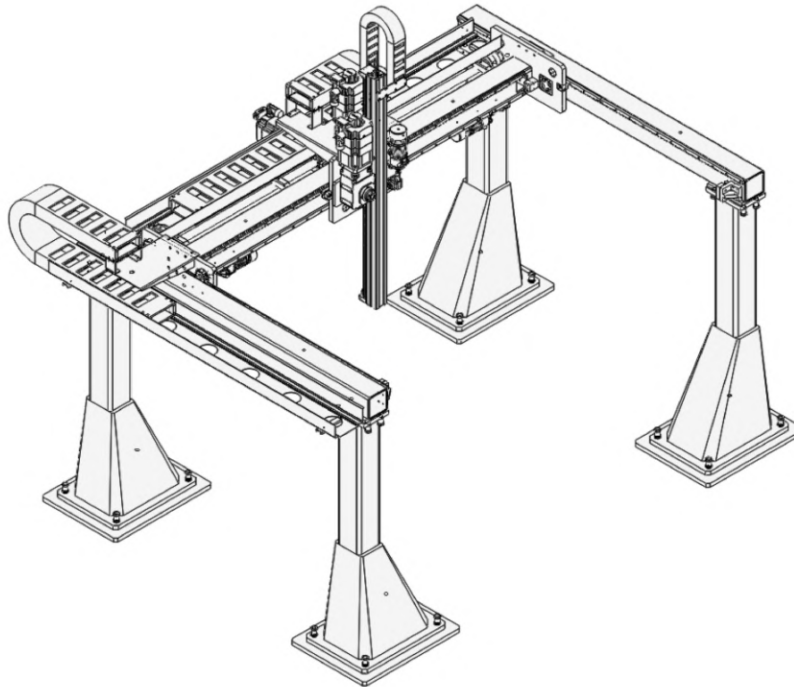

最大负载能力 Max. Payload	15kg
X轴最大移动速度 Max. Speed for X axis	150m/min.
X轴最大加速度 Max. acc. Speed for X axis	2 m/s <sup>2</sup>
Y轴最大移动速度 Max. Speed for Y axis	150m/min.
Y轴最大加速度 Max. acc. Speed for Y axis	5 m/s <sup>2</sup>
Z轴最大移动速度 Max. Speed for Z axis	120m/min.
Z轴最大加速度 Max. acc. Speed for Z axis	10m /s <sup>2</sup>
Y轴标准行程 Standard stroke for Y axis	2500mm
Z轴标准行程 Standard stroke for Z axis	700mm
重复定位精度 Repeatability accuracy	±0.02mm
驱动方式 Drive	齿轮齿条 Rack & pinion
控制方式 El. control	伺服控制 Servo control

X轴

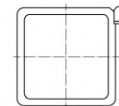

Y轴

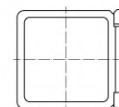

Z轴



**龙门三轴桁架机器人 HG-40**  
**Double-beam 3-axis gantry robot HG-40**

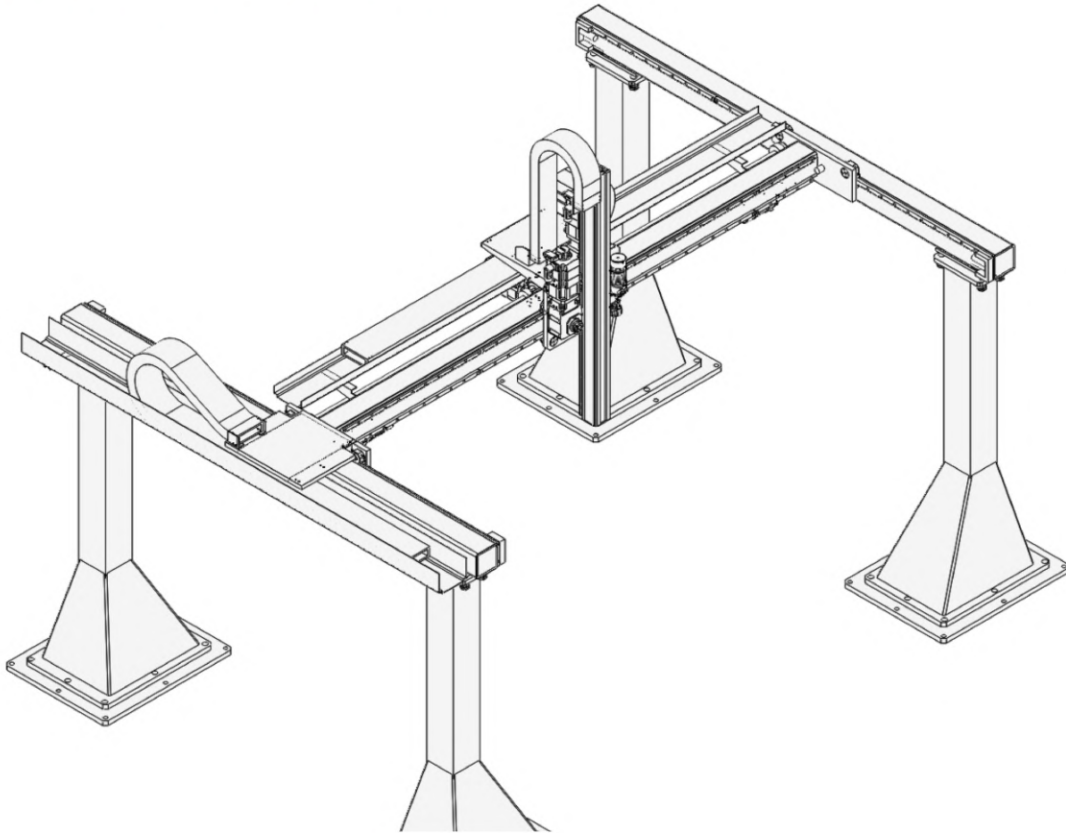

最大负载能力 Max. Payload	40kg
X轴最大移动速度 Max. Speed for X axis	120m/min.
X轴最大加速度 Max. acc. Speed for X axis	2 m/s <sup>2</sup>
Y轴最大移动速度 Max. Speed for Y axis	120m/min.
Y轴最大加速度 Max. acc. Speed for Y axis	4 m/s <sup>2</sup>
Z轴最大移动速度 Max. Speed for Z axis	75m/min.
Z轴最大加速度 Max. acc. Speed for Z axis	3m /s <sup>2</sup>
Y轴标准行程 Standard stroke for Y axis	3000mm
Z轴标准行程 Standard stroke for Z axis	1000mm
重复定位精度 Repeatability accuracy	±0.02mm
驱动方式 Drive	齿轮齿条 Rack & pinion
控制方式 El. control	伺服控制 Servo control

X轴

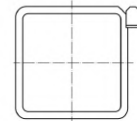

Y轴

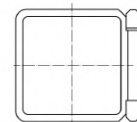

Z轴



龙门三轴桁架机器人 HG-150  
Double-beam 3-axis gantry robot HG-150

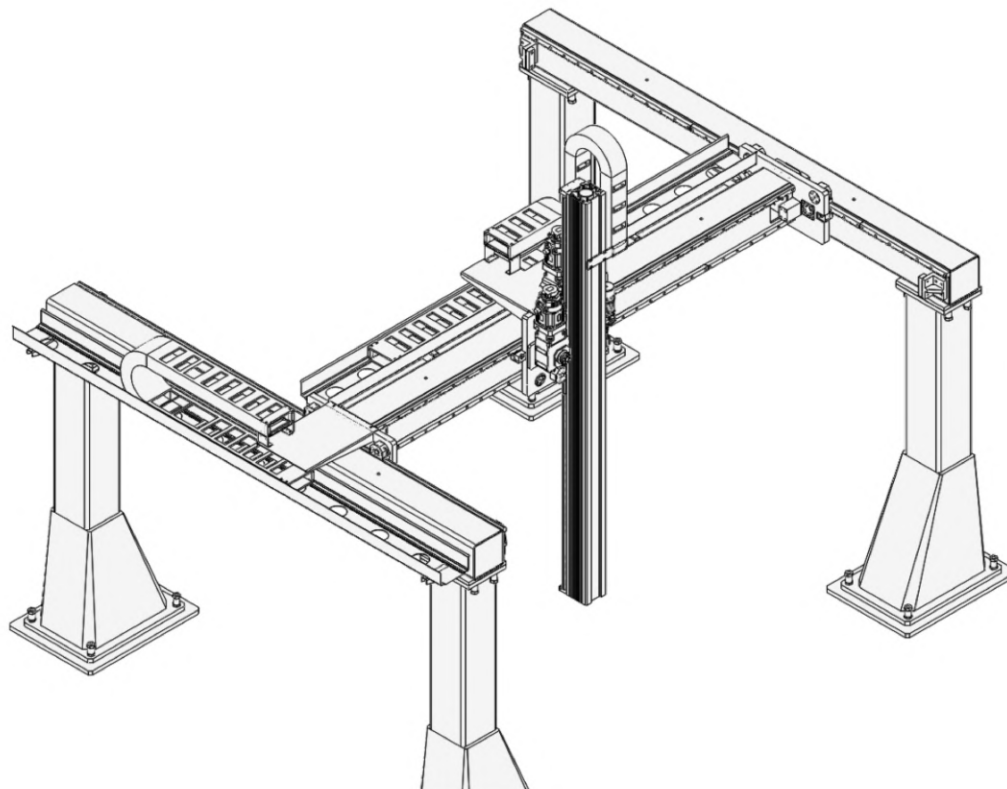

最大负载能力 Max. Payload	150kg
X轴最大移动速度 Max. Speed for X axis	60m/min.
X轴最大加速度 Max. acc. Speed for X axis	1 m/s <sup>2</sup>
Y轴最大移动速度 Max. Speed for Y axis	60m/min.
Y轴最大加速度 Max. acc. Speed for Y axis	2 m/s <sup>2</sup>
Z轴最大移动速度 Max. Speed for Z axis	42m/min.
Z轴最大加速度 Max. acc. Speed for Z axis	1m /s <sup>2</sup>
Y轴标准行程 Standard stroke for Y axis	4000mm
Z轴标准行程 Standard stroke for Z axis	1200mm
重复定位精度 Repeatability accuracy	±0.02mm
驱动方式 Drive	齿轮齿条 Rack & pinion
控制方式 El. control	伺服控制 Servo control

X轴

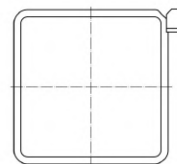

Y轴

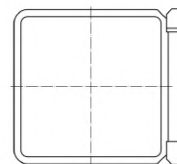

Z轴

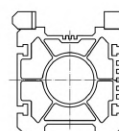

### 龙门三轴桁架机器人 HG-400

#### Double-beam 3-axis gantry robot HG-400

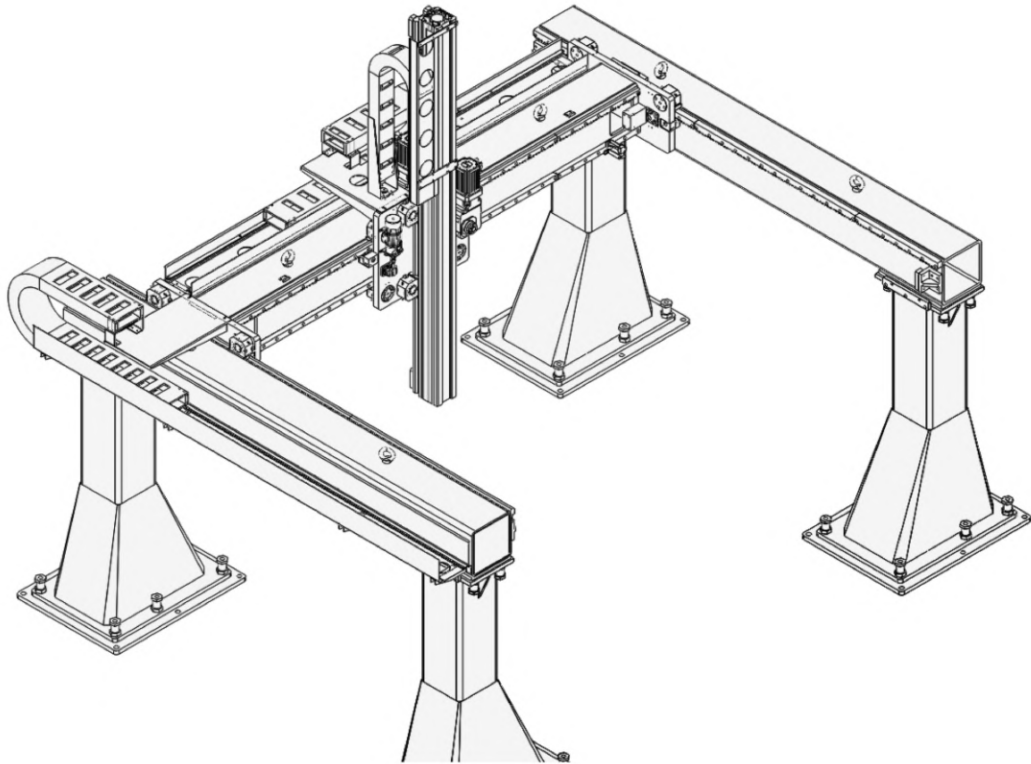

最大负载能力 Max. Payload	400kg
X轴最大移动速度 Max. Speed for X axis	60m/min.
X轴最大加速度 Max. acc. Speed for X axis	1 m/s <sup>2</sup>
Y轴最大移动速度 Max. Speed for Y axis	60m/min.
Y轴最大加速度 Max. acc. Speed for Y axis	2 m/s <sup>2</sup>
Z轴最大移动速度 Max. Speed for Z axis	36m/min.
Z轴最大加速度 Max. acc. Speed for Z axis	1m /s <sup>2</sup>
Y轴标准行程 Standard stroke for Y axis	6000mm
Z轴标准行程 Standard stroke for Z axis	1600mm
重复定位精度 Repeatability accuracy	±0.02mm
驱动方式 Drive	齿轮齿条 Rack & pinion
控制方式 El. control	伺服控制 Servo control

X轴

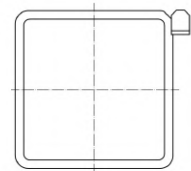

Y轴

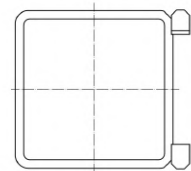

Z轴

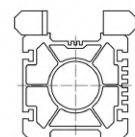

**龙门三轴桁架机器人 HG-1000**  
**Double-beam 3-axis gantry robot HG-1000**

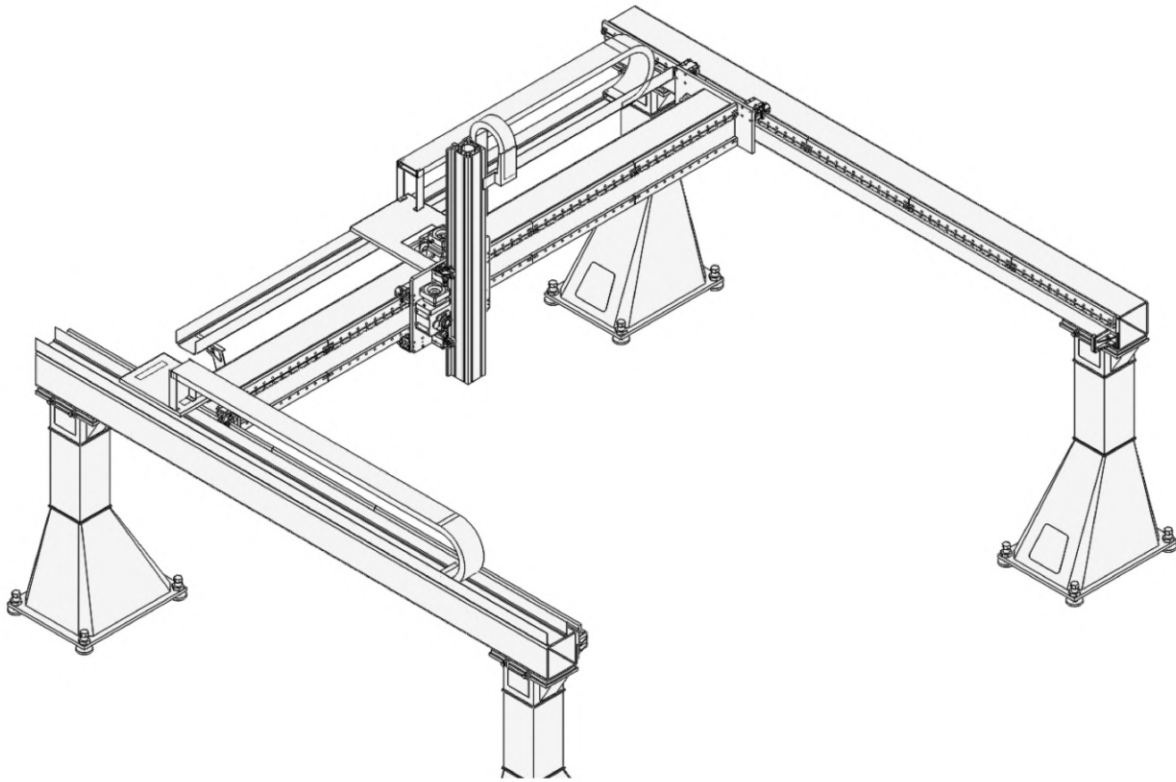

最大负载能力 Max. Payload	1000kg
X轴最大移动速度 Max. Speed for X axis	42m/min.
X轴最大加速度 Max. acc. Speed for X axis	1 m/s <sup>2</sup>
Y轴最大移动速度 Max. Speed for Y axis	42m/min.
Y轴最大加速度 Max. acc. Speed for Y axis	1 m/s <sup>2</sup>
Z轴最大移动速度 Max. Speed for Z axis	30m/min.
Z轴最大加速度 Max. acc. Speed for Z axis	0.5m /s <sup>2</sup>
Y轴标准行程 Standard stroke for Y axis	8000mm
Z轴标准行程 Standard stroke for Z axis	1600mm
重复定位精度 Repeatability accuracy	±0.02mm
驱动方式 Drive	齿轮齿条 Rack & pinion
控制方式 El. control	伺服控制 Servo control

X轴

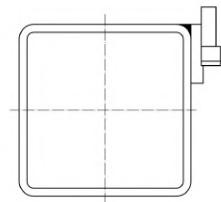

Y轴

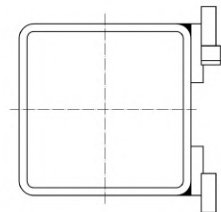

Z轴

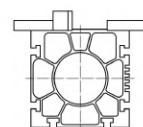

龙门三轴桁架机器人 HG-2500  
Double-beam 3-axis gantry robot HG-2500

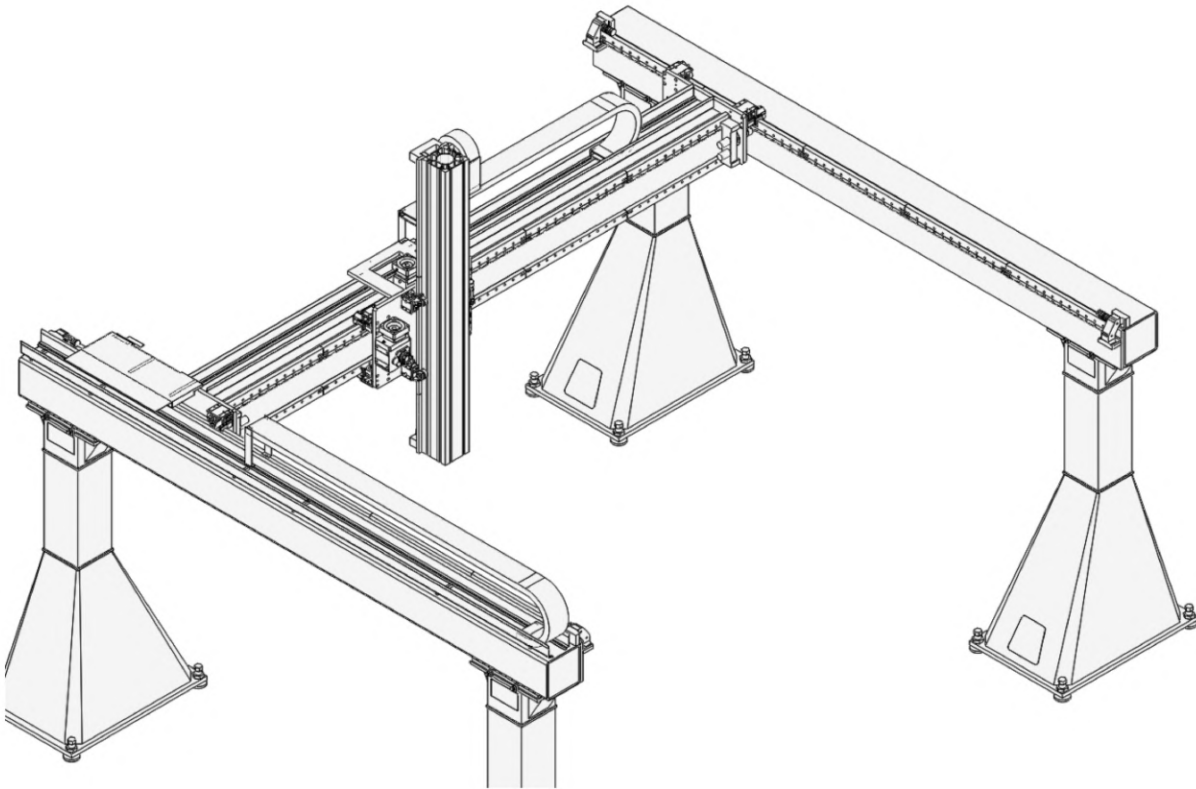

最大负载能力 Max. Payload	2500kg
X轴最大移动速度 Max. Speed for X axis	42m/min.
X轴最大加速度 Max. acc. Speed for X axis	1 m/s <sup>2</sup>
Y轴最大移动速度 Max. Speed for Y axis	42m/min.
Y轴最大加速度 Max. acc. Speed for Y axis	1m/s <sup>2</sup>
Z轴最大移动速度 Max. Speed for Z axis	30m/min.
Z轴最大加速度 Max. acc. Speed for Z axis	0.5m /s <sup>2</sup>
Y轴标准行程 Standard stroke for Y axis	10000mm
Z轴标准行程 Standard stroke for Z axis	1600mm
重复定位精度 Repeatability accuracy	±0.02mm
驱动方式 Drive	齿轮齿条 Rack & pinion
控制方式 El. control	伺服控制 Servo control

X轴

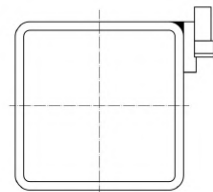

Y轴

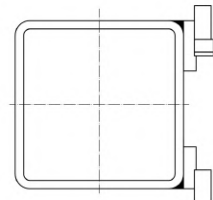

Z轴

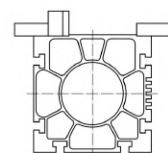



## 机器人行走轴 Travelling Tracks for Robots

摩云阁机器人行走轴（又称机器人第七轴）系列产品基于摩云阁V型导轨齿条传动系统和扁导轨齿条传动系统设计，具有精度高、速度快、结构紧凑、低噪音等优势。模块化设计可实现零部件灵活组合，自由搭建单轴、多轴及旋转模块，适配发那科、ABB、库卡、安川等多品牌机器人。专业技术团队，可以根据客户需求，快速提供机器人自动化解决方案，并实现设计、生产、装配、调试到售后服务的全程控制。最大机器人负载能力从300kg-3000kg提供多款选择。可定制化设计，完美匹配各类自动化工艺与设备需求。

MOVING-GOODS Travelling Tracks for Robots (7th axis/linear tracks/RTU) are designed based on MOVING-GOODS Guideway Rack Drive Systems, featuring high precision, high speed, space-saving and low noise. The modular design enables flexible combination of components to form single-axis, multiple-axis and rotary modules. The products are fully compatible with robots of FANUC, ABB, KUKA, Yaskawa and other brands.

Models available with maximum payload from 300kg to 3000kg. Customized design is available to meet the automation processes and equipment.

**机器人行走轴 GT-300**  
**Travelling Track for Robot GT-300**

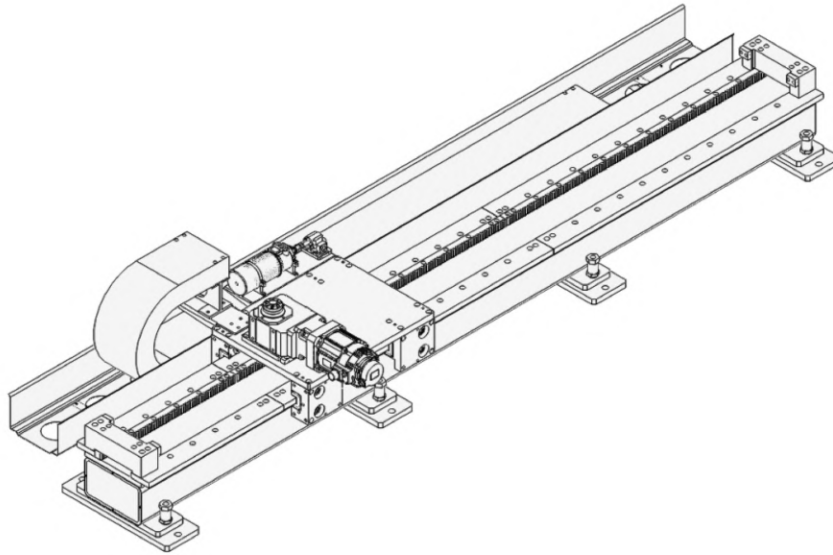

最大机器人负载能力 Max. Capacity to carry robot	300Kg
最大静载荷负载能力 Max. Capacity to carry static load	1200Kg
最大机器人负载移动速度 Max. Speed to carry robot	180m/min.
最大机器人负载加速度 Max. acc. Speed to carry robot	8 m/s <sup>2</sup>
最大静载荷移动速度 Max. Speed to carry static load	120m/min.
最大静载荷加速度 Max. acc. Speed to carry static load	3 m/s <sup>2</sup>
重复定位精度 Repeatability Accuracy	±0.02mm
驱动方式 Drive	齿轮齿条 Rack & pinion
控制方式 El. Control	伺服控制 Servo control

**机器人行走轴 GT-900**  
**Travelling Track for Robot GT-900**

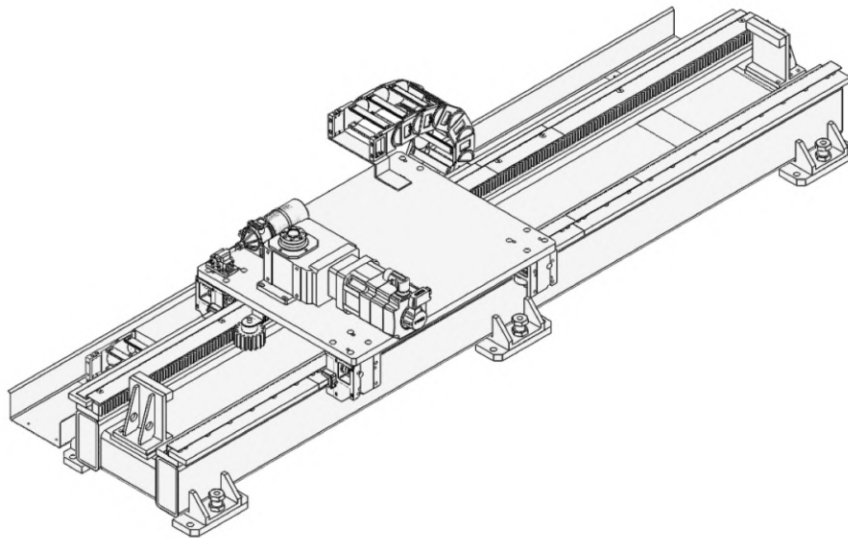

最大机器人负载能力 Max. Capacity to carry robot	900Kg
最大静载荷负载能力 Max. Capacity to carry static load	2500Kg
最大机器人负载移动速度 Max. Speed to carry robot	150m/min.
最大机器人负载加速度 Max. acc. Speed to carry robot	4 m/s <sup>2</sup>
最大静载荷移动速度 Max. Speed to carry static load	90m/min.
最大静载荷加速度 Max. acc. Speed to carry static load	1.5 m/s <sup>2</sup>
重复定位精度 Repeatability Accuracy	±0.02mm
驱动方式 Drive	齿轮齿条 Rack & pinion
控制方式 El. Control	伺服控制 Servo control

**机器人行走轴 GT-2000**  
**Travelling Track for Robot GT-2000**

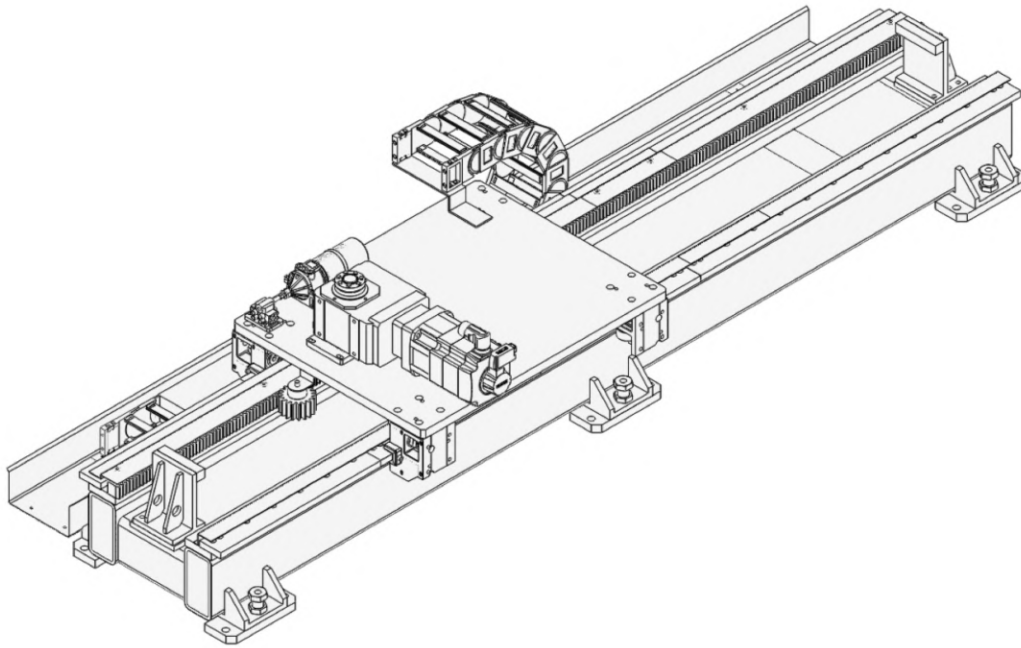

最大机器人负载能力 Max. Capacity to carry robot	2000Kg
最大静载荷负载能力 Max. Capacity to carry static load	4000Kg
最大机器人负载移动速度 Max. Speed to carry robot	150m/min.
最大机器人负载加速度 Max. acc. Speed to carry robot	3 m/s <sup>2</sup>
最大静载荷移动速度 Max. Speed to carry static load	90m/min.
最大静载荷加速度 Max. acc. Speed to carry static load	2 m/s <sup>2</sup>
重复定位精度 Repeatability Accuracy	±0.02mm
驱动方式 Drive	齿轮齿条 Rack & pinion
控制方式 El. Control	伺服控制 Servo control

**机器人行走轴 GT-3000**  
**Travelling Track for Robot GT-3000**

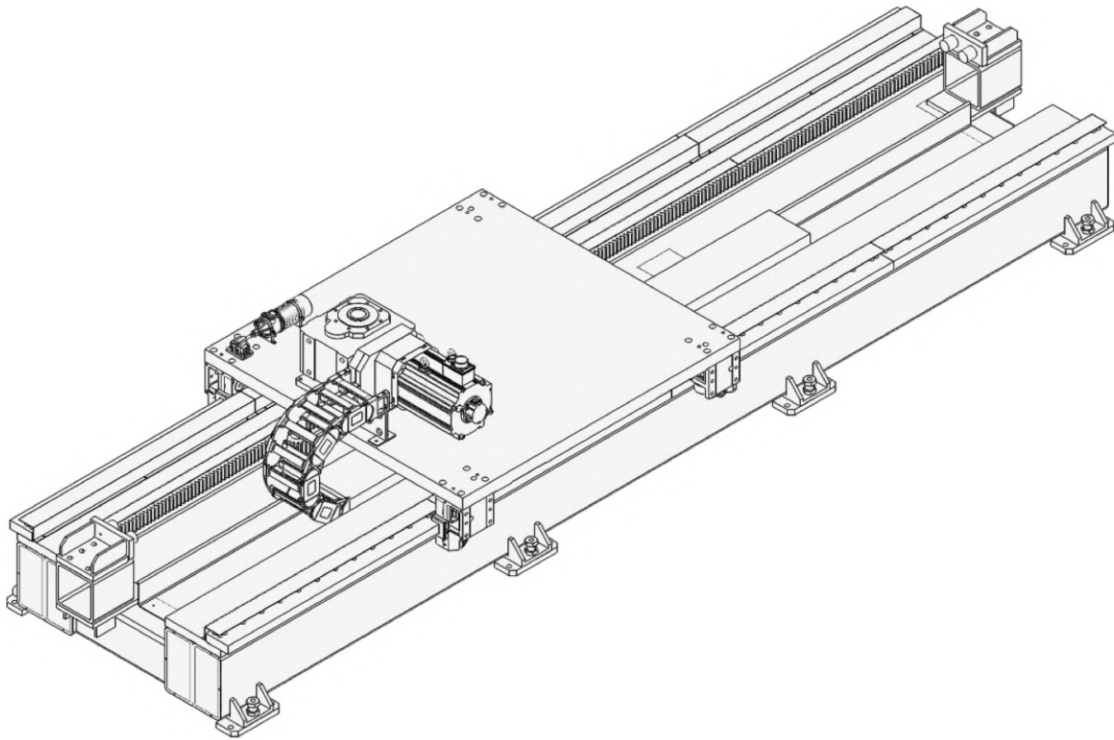

最大机器人负载能力 Max. Capacity to carry robot	3000Kg
最大静载荷负载能力 Max. Capacity to carry static load	5200Kg
最大机器人负载移动速度 Max. Speed to carry robot	120m/min.
最大机器人负载加速度 Max. acc. Speed to carry robot	3 m/s <sup>2</sup>
最大静载荷移动速度 Max. Speed to carry static load	90m/min.
最大静载荷加速度 Max. acc. Speed to carry static load	2 m/s <sup>2</sup>
重复定位精度 Repeatability Accuracy	±0.02mm
驱动方式 Drive	齿轮齿条 Rack & pinion
控制方式 El. Control	伺服控制 Servo control



## 自动化解决方案 Automation Solutions

摩云阁自动化解决方案基于摩云阁导轨齿条传动系统及桁架机器人设计，具有模块化、精度高、速度快、结构紧凑、低噪音等优势。与台达、西门子、发那科、ABB、库卡、安川等品牌的战略合作，可为桁架机器人配置多款伺服控制系统及机械手臂，全方位满足各行业客户需求。专业技术团队，可以根据客户需求，快速提供机器人自动化解决方案，并实现设计、生产、装配、调试到售后服务的全程控制。

MOVING-GOODS Automation Solutions are designed based on MOVING-GOODS Guideway Rack Drive Systems and Gantry Robots, the products feature modular design, high precision, high speed, space-saving and low noise. Through strategic partnerships with Delta, Siemens, FANUC, ABB, KUKA, Yaskawa and other brands, we can equip gantry robots with a variety of servo control systems and robotic arms.

Our professional technical team can rapidly provide robotic automation solutions tailored to customer needs, ensuring full-process control from design, production, assembly and commissioning to after-sales service.

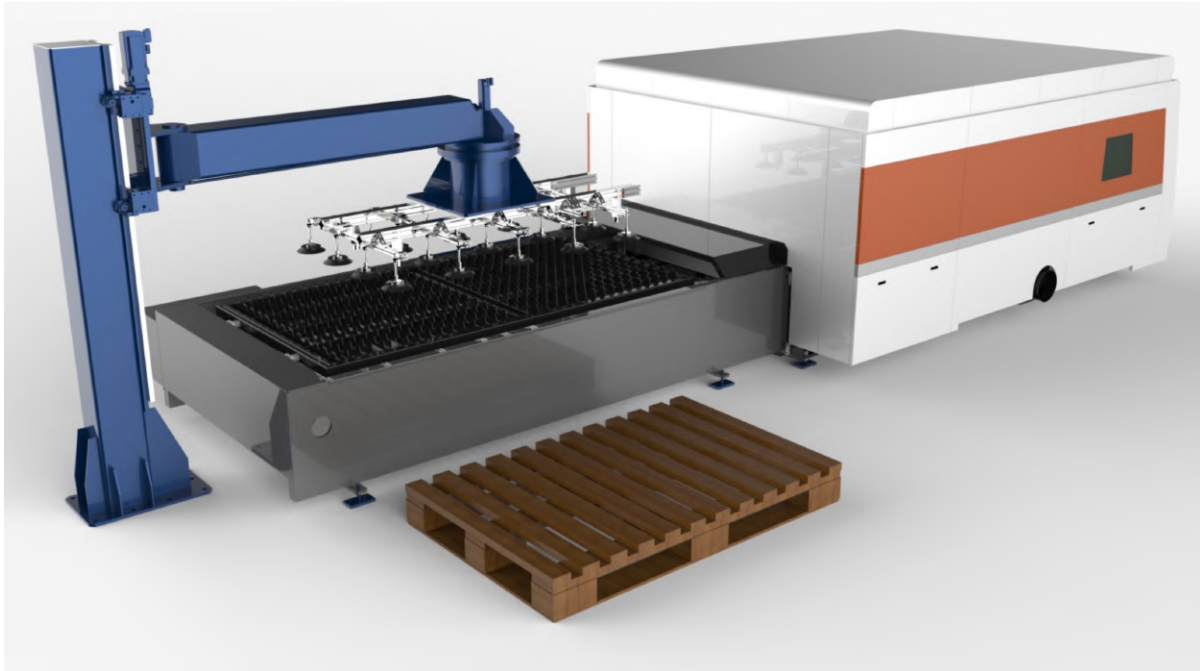

## 旋转式钢板上下料设备

### Rotary Loader for Laser Cutting Machine

摩云阁旋转式钢板上下料设备，是专为激光切割机打造的紧凑型自动化上下料解决方案。基于摩云阁自研高精度导轨齿条传动系统，搭载 360° 旋转式机械臂与智能真空吸盘，可一站式完成钢板原料取料、精准上料、切割成品下料全流程作业。是钣金加工、汽车制造、五金等行业实现切割产线无人化升级的高性价比之选。

- 旋转结构省空间，适配中小产线
- 精密齿条传动，精度高、寿命长
- 兼容多规格激光切割机，柔性生产
- 全流程自动化，降本增效、安全可靠

Rotary Loader for Laser Cutting Machine is a compact automated loading and unloading solution tailor-made for laser cutting machines. Designed based on MOVING-GOODS Guideway Rack Drive Systems, it is equipped with a 360° rotary manipulator and intelligent vacuum suction cups. It can complete the whole process including steel plate picking, precise loading and finished part unloading in one-stop operation. It is a cost-effective choice for achieving unmanned laser cutting lines in sheet metal processing, automotive, hardware and other industries.

- Space-saving rotary design - ideal for small to medium production lines
- Precision rack drive - high accuracy and long service life
- Flexible production - compatible with multiple models of laser cutting machines
- Fully automated process - cost reduction, efficiency increase, safe and reliable

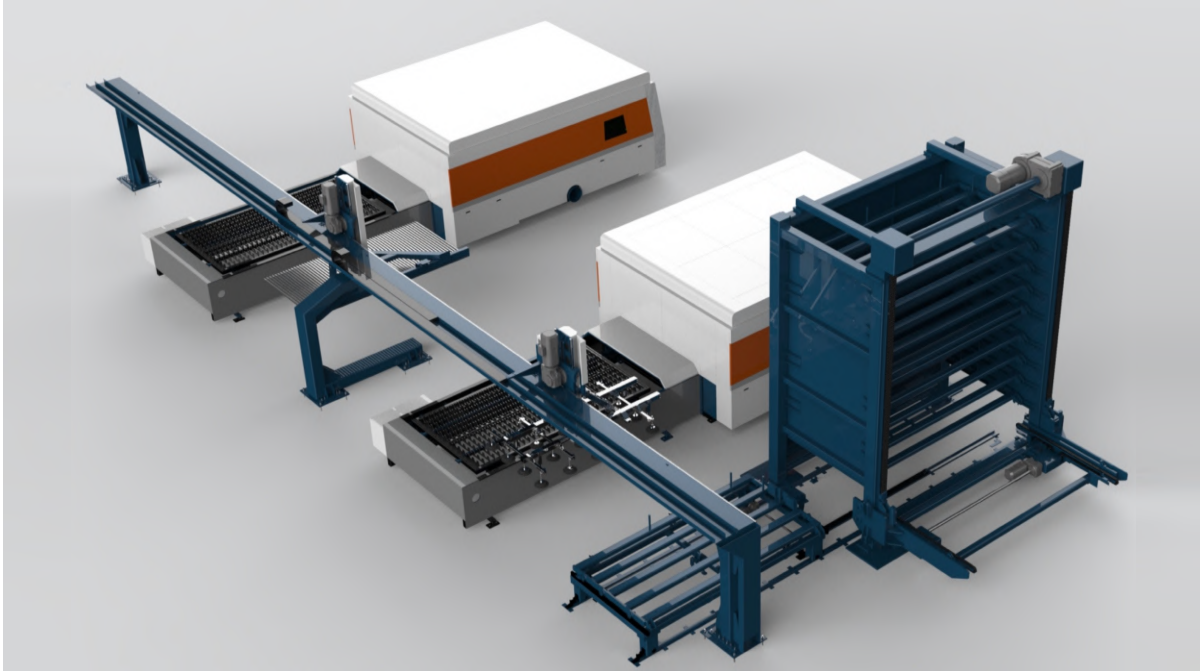

## 桁架式钢板上下料设备（带料库）

### Gantry Loader for Laser Cutting Machine with Steel Plate Bank

摩云阁旋转式钢板上下料设备，是专为激光切割机打造的紧凑型自动化上下料解决方案。基于摩云阁自研高精度导轨齿条传动系统，搭载 360° 旋转式机械臂与智能真空吸盘，可一站式完成钢板原料取料、精准上料、切割成品下料全流程作业。是钣金加工、汽车制造、五金等行业实现切割产线无人化升级的高性价比之选。

- 旋转结构省空间，适配中小产线
- 精密齿条传动，精度高、寿命长
- 兼容多规格激光切割机，柔性生产
- 全流程自动化，降本增效、安全可靠

Rotary Loader for Laser Cutting Machine is a compact automated loading and unloading solution tailor-made for laser cutting machines. Designed based on MOVING-GOODS Guideway Rack Drive Systems, it is equipped with a 360° rotary manipulator and intelligent vacuum suction cups. It can complete the whole process including steel plate picking, precise loading and finished part unloading in one-stop operation. It is a cost-effective choice for achieving unmanned laser cutting lines in sheet metal processing, automotive, hardware and other industries.

- Space-saving rotary design - ideal for small to medium production lines
- Precision rack drive - high accuracy and long service life
- Flexible production - compatible with multiple models of laser cutting machines
- Fully automated process - cost reduction, efficiency increase, safe and reliable

**客户需求参数表**  
 Customer Request Form

桁架机器人参数 Technical Data for Gantry Robot			
客户名称 Customer:			
No.	名称 Item	参数 Data	单位 Unit
1	Z轴末端负载 (夹具+工件) Load (gripper + workpiece) under end of Z axis		KG
2	工件尺寸 Size of workpiece		mm
3	X轴速度 Speed for X axis		m/s
4	X轴加速度 Acc. Speed for X axis		m/s <sup>2</sup>
5	X轴行程 Stroke for X axis		m
6	Y轴速度 Speed for Y axis		m/s
7	Y轴加速度 Acc. Speed for Y axis		m/s <sup>2</sup>
8	Y轴行程 Stroke for Y axis		m
9	Z轴速度 Speed for Z axis		m/s
10	Z轴加速度 Acc. Speed for Z axis		m/s <sup>2</sup>
11	Z轴行程 Stroke for Z axis		m
12	立柱高度 Column Height		mm
13	项目发货地址 Project Location		
14	其他要求 Other Request		

机器人行走轴参数 Technical Data for Travelling Track for Robot			
客户名称 Customer:			
No.	名称 Item	参数 Data	单位 Unit
1	机器人品牌型号 Robot Brand & Model		
2	机器人自重+ 载荷 Robot Weight + Load		KG
3	速度要求 Speed		m/s
4	加速度要求 Acc. Speed		m/s <sup>2</sup>
5	行程 Stroke		m
6	重复定位精度 Repeatibility Accuracy		mm
7	机器人是否需配增高底座 Robot base to be raised or not		
8	项目发货地址 Project Location		
9	其他要求 Other Requests		

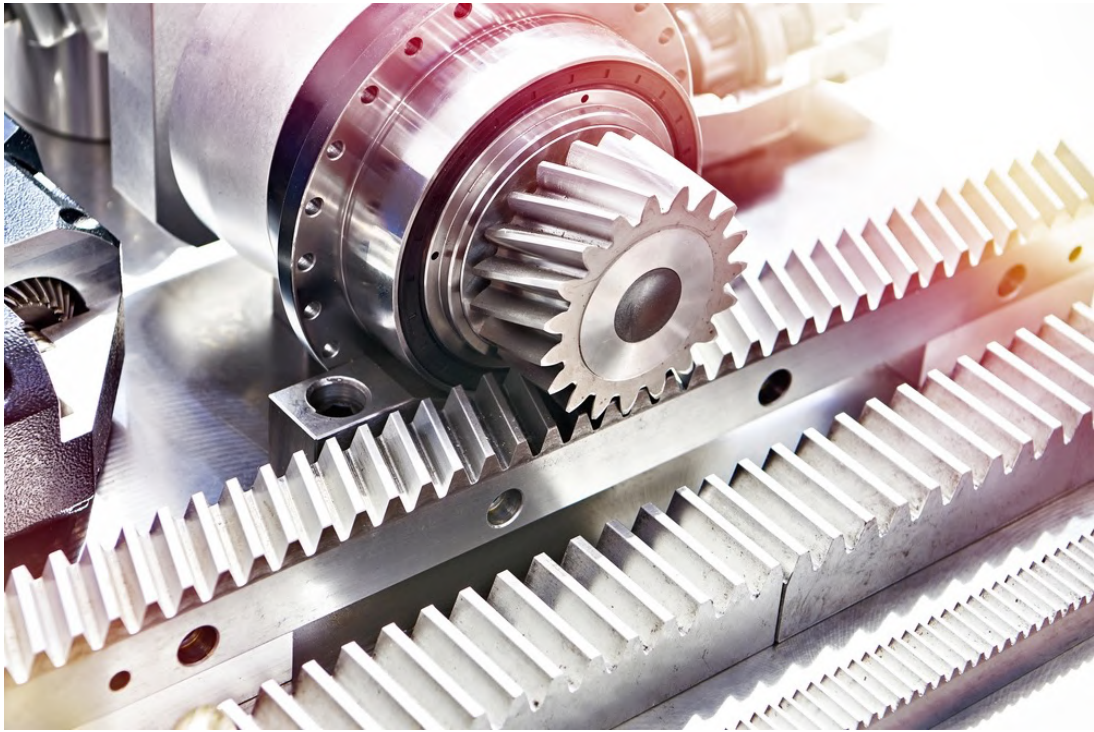

齿条及传动系统  
Racks & Drive Systems

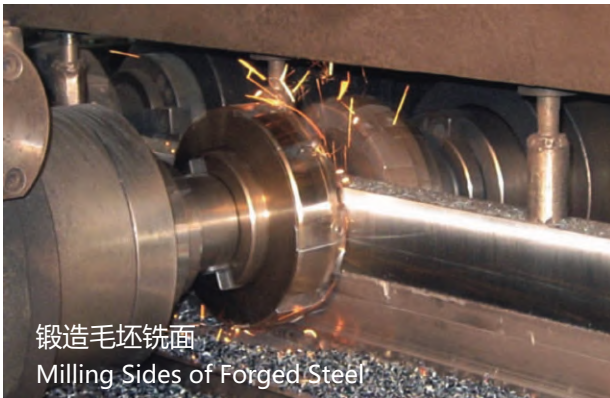

锻造毛坯铣面  
Milling Sides of Forged Steel



铣齿  
Milling Teeth



数控磨齿机  
CNC Rack Grinding Machine



三坐标测量仪  
Coordinate Measuring Machine

齿条加工工艺及设备  
Rack Manufacturing Process and Equipment

# 直行有道 智控无疆

## Smarter Linear Motion



摩云阁香河机器人有限公司  
BMG Robot (Xianghe) Co., Ltd.

地址: 河北香河经济开发区运平路28号

Address: No. 28 Yunping Road, Xianghe Economic Development Zone, Hebei, China

Tel: +86-10-89580750, Sales: +86-13810254586, 15011317132

Email: [info@bmg-racks.com](mailto:info@bmg-racks.com)

[www.bmg-racks.com](http://www.bmg-racks.com)